

Lab 4 Phase Shift Oscillator

A phase-shift oscillator is shown in the following figure. In order to obtain sustained oscillation, the phase margin and gain margin of the circuit must be set to zero. This zero margin condition is equivalent to the condition that the complex poles of the circuit are on the imaginary axes. In this lab we will use the frequency domain stability analysis method to determine the value of the feedback gain K .

The circuit consists of a 3-stage RC filter, a voltage follower, and an inverting amplifier. The inverting amplifier's gain is $-R/1k$ where the resistance R is to be determined. The dynamics of the circuit is determined by the 3-stage RC filter. Each RC stage can provide up to 90 degrees of phase shift. With 3 such stages connected in cascade, the total phase shift can reach 270 degrees at high frequency. In order to obtain zero phase margin, the feedback gain must be set so that the loop gain is unity at the cross over frequency.

In practice, it is impossible to keep the phase margin exactly at zero as required for an oscillator producing constant amplitude output. In other words, the poles of the circuit cannot be positioned exactly on the imaginary axes. If the phase margin becomes negative (i.e., poles shift slightly to the right of the imaginary axes) the output signal's amplitude will increase exponentially. If the phase margin is positive (i.e., poles shift to the left), the output amplitude will decrease exponentially. A solution to this problem is to introduce a slight nonlinearity into the circuit and this is the purpose of the Zener diodes.

The impedance of a set of back-to-back Zener diodes connected in series is infinite and, therefore the gain of the op amp circuit is $-R/1k$. Suppose R is selected so that the poles are slightly on the right side of the imaginary axes. With this RHP poles, the output voltage will gradually increase. When the output voltage reaches the Zener voltage, the Zener circuit starts to conduct and the op amp feedback impedance drops. This lower feedback impedance renders lower loop gain and, hence, shifts the poles back to the left of the axes. Consequently, the output amplitude is kept under a certain value.

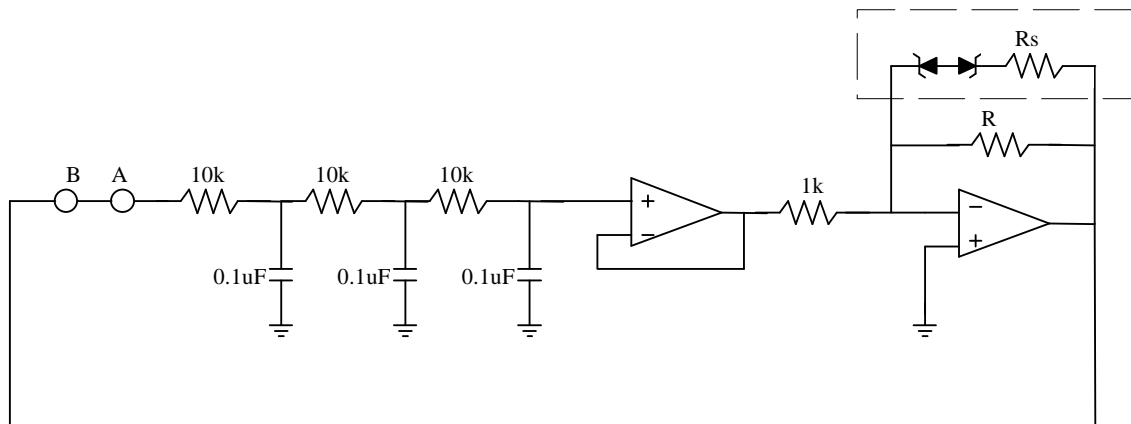

Prelab

- (1) **Optional:** If you need to refresh your memory about Nyquist plots and the Nyquist stability criterion (covered in EECS120), read section 6.3 (pages 390-402).
- (2) Why do we need to add a non-linearity to the oscillator circuit?
- (3) Read section 6.4 of the textbook (pages 403-411). Give the definitions of the terms: *gain margin*, *phase margin*, and *crossover frequency*. Also, give a brief explanation about the importance of these values and about how to determine the values from the Bode plot.

Lab procedure

- (1) Derive the loop transfer function from A to B. In other words, find the transfer function from point A to B assuming that there is no direct connection between B and A as in the actual circuit. Assume $R=1k$ (i.e., unity gain amplifier) and ignore the Zener diodes and the resistor R_s in your derivation.
- (2) Generate a Bode pole for the loop transfer function obtained in step (1) and determine the cross over frequency and the value of R that renders zero phase margin.
- (3) Construct the 3-stage RC filter and experimentally determine its frequency response. In particular, find the frequency and the loop transfer function magnitude at which the phase shift is 180 degrees. Do these values agree with the values obtained in step (2)?
- (4) Construct the circuit without the Zener diodes. Use a variable resistor for R and preset its value to the value found in step (2).
- (5) Observe the output with a scope. If the circuit does not oscillate, increase the value of R by 10%. Record the output waveform.
- (6) Install the Zener diode and the value of R_s to ten times the value of R . Record the waveform.
- (7) What is the purpose of the voltage follower amplifier? How will the circuit operation change if this voltage follower is replaced by a straight through wire?