

PIN CONFIGURATION						
PIN NO.	SYMBOL	LEVEL	FUNCTION			
1	V _{DD}	-	POWER SUPPLY	5V		
2	V _{SS}	-		GND (0V)		
3	V _O	-		FOR LCD DRIVE		
4	RS	H/L	REGISTER SELECT SIGNAL H: DATA INPUT L: INSTRUCTION INPUT			
5	R/W	H/L	H: DATA READ (MODULE-->MPU) L: DATA WRITE (MODULE<--MPU)			
6	E	H _H ->L	ENABLE			
7~14	DB0~DB7	H/L	DATA BUS--SOFTWARE SELECTABLE 4 OR 8 BIT MODE.			

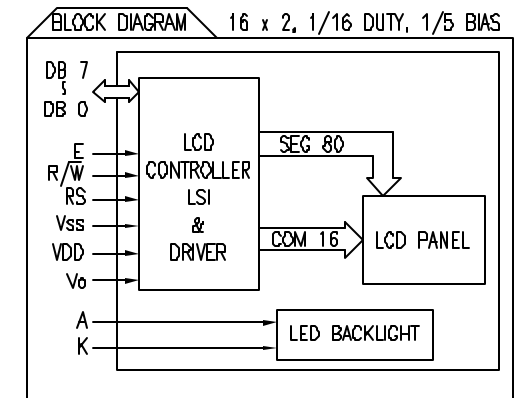
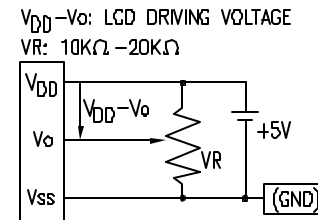

ELECTRICAL CHARACTERISTICS		V _{DD} =4.7V to 5.3V, T _A =25°C					
ITEM	SYMBOL	CONDITION	STANDARD VALUE			UNIT	
			MIN.	TYP.	MAX.		
SUPPLY VOLTAGE FOR LOGIC	V _{DD} -V _{SS}	-	-	5.0	-	V	
SUPPLY CURRENT FOR LOGIC	I _{DD}	V _{DD} =5V	-	2.0	3.0	mA	
INPUT VOLTAGE	HIGH	V _{IH}	-	2.2	-	V _{DD}	
	LOW	V _{IL}	-	0	-	0.6	
OUTPUT VOLTAGE	HIGH	V _{OH}	-	2.4	-	V	
	LOW	V _{OL}	-	-	0.4	V	
LED BACKLIGHT	VOLTAGE	V _f	I _f =160mA	-	4.2	4.6	V
	CURRENT	I _f	-	-	160	-	mA
	POWER CONSUMPTION	PD	-	-	656	-	mW
	LUMINOUS	L	I _f =160mA	70	-	-	cd/m ²
	COLOR	-	-	-	-	-	nm

ABSOLUTE MAXIMUM RATINGS					
ITEM	SYMBOL	TEST CONDITION	STANDARD VALUE		UNIT
SUPPLY VOLTAGE FOR LOGIC	V _{DD} -V _{SS}	T _a =25°C	4.7	5.3	V
SUPPLY VOLTAGE FOR LCD DRIVE	V _{DD} -V _O	-	4.2@50°C	4.8@0°C	V
INPUT VOLTAGE	V _I	T _a =25°C	V _{SS}	V _{DD}	V
OPERATING TEMPERATURE	T _{opr}	LCM-S	0	50	°C
STORAGE TEMPERATURE	T _{stg}	LCM-S	-20	70	°C

*UNLESS OTHERWISE SPECIFIED TOLERANCES PER DECIMAL PRECISION ARE: X=±1 (±0.039), XX=±0.5 (±0.020), XXX=±0.25 (±0.010), XXXX=±0.127 (±0.005). LEAD SIZE=±0.05 (±0.002), LEAD LENGTH=±0.75 (±0.030). MIN.= +DECIMAL PRECISION -0.00 MAX.= +0.00 -DECIMAL PRECISION

REV.	PART NUMBER LCM-S01602DSF/C
5.56mm CHARACTER HEIGHT, 5 x 8 DOT MATRIX, 16 x 2 LCD MODULE, 1/16 DUTY, 1/5 BIAS.	

CONFIDENTIAL INFORMATION
THE INFORMATION CONTAINED IN THIS DOCUMENT IS THE PROPERTY OF LUMEX INC. EXCEPT AS SPECIFICALLY AUTHORIZED IN WRITING BY LUMEX INC., THE HOLDER OF THIS DOCUMENT SHALL KEEP ALL INFORMATION CONTAINED HEREIN CONFIDENTIAL AND SHALL PROTECT SAME IN WHOLE OR IN PART FROM DISCLOSURE AND DISSEMINATION TO ALL THIRD PARTIES.

RELIABILITY NOTE
OUR MANY YEARS OF EXPERIENCE DATA ACCUMULATION INDICATE THAT SOLDER HEAT IS A MAJOR CAUSE OF EARLY AND FUTURE FAILURE. PLEASE PAY ATTENTION TO YOUR SOLDERING PROCESS.

290 E. HELEN ROAD
PALATINE, IL 60067-6976
PHONE: +1.847.359.2790
US WEB: www.lumex.com
TW WEB: www.lumex.com.tw

DRAWN BY: ct	CHECKED BY:	APPROVED BY:	DATE: 10.30.01
			PAGE: 1 OF 2
			SCALE: N/A