

## RECOMMENDATION ITU-R BT.656-4

**INTERFACES FOR DIGITAL COMPONENT VIDEO SIGNALS IN 525-LINE  
AND 625-LINE TELEVISION SYSTEMS OPERATING AT THE 4:2:2  
LEVEL OF RECOMMENDATION ITU-R BT.601 (PART A)**

(Question ITU-R 65/11)

(1986-1992-1994-1995-1998)

The ITU Radiocommunication Assembly,

*considering*

- a) that there are clear advantages for television broadcasting organizations and programme producers in digital studio standards which have the greatest number of significant parameter values common to 525-line and 625-line systems;
- b) that a worldwide compatible digital approach will permit the development of equipment with many common features, permit operating economies and facilitate the international exchange of programmes;
- c) that to implement the above objectives, agreement has been reached on the fundamental encoding parameters of digital television for studios in the form of Recommendation ITU-R BT.601;
- d) that the practical implementation of Recommendation ITU-R BT.601 requires definition of details of interfaces and the data streams traversing them;
- e) that such interfaces should have a maximum of commonality between 525-line and 625-line versions;
- f) that in the practical implementation of Recommendation ITU-R BT.601 it is desirable that interfaces be defined in both serial and parallel forms;
- g) that digital television signals produced by these interfaces may be a potential source of interference to other services, and due notice must be taken of No. 964 of the Radio Regulations (RR),

*recommends*

that where interfaces are required for component-coded digital video signals described in Recommendation ITU-R BT.601 (Part A) in television studios, the interfaces and the data streams that will traverse them should be in accordance with the following description, defining both bit-parallel and bit-serial implementations.

## **1 Introduction**

This Recommendation describes the means of interconnecting digital television equipment operating on the 525-line or 625-line standards and complying with the 4:2:2 encoding parameters as defined in Recommendation ITU-R BT.601 (Part A).

Part 1 describes the signal format common to both interfaces.

Part 2 describes the particular characteristics of the bit-parallel interface.

Part 3 describes the particular characteristics of the bit-serial interface.

Supplementary information is to be found in Annex 1.

## PART 1

## Common signal format of the interfaces

**1 General description of the interfaces**

The interfaces provide a unidirectional interconnection between a single source and a single destination.

A signal format common to both parallel and serial interfaces is described in § 2.

The data signals are in the form of binary information coded in 8-bit or, optionally, 10-bit words (see Note 1). These signals are:

- video signals,
- timing reference signals,
- ancillary signals.

NOTE 1 – Within this Recommendation, the contents of digital words are expressed in both decimal and hexadecimal form. To avoid confusion between 8-bit and 10-bit representations, the eight most significant bits are considered to be an integer part while the two additional bits, if present, are considered to be fractional parts.

For example, the bit pattern 10010001 would be expressed as 145<sub>d</sub> or 91<sub>h</sub>, whereas the pattern 1001000101 is expressed as 145.25<sub>d</sub> or 91.4<sub>h</sub>.

Where no fractional part is shown, it should be assumed to have the binary value 00.

Eight-bit words occupy the left most significant bits of a 10-bit word, i.e. bit 9 to bit 2, where bit 9 is the most significant bit.

**2 Video data****2.1 Coding characteristics**

The video data is in compliance with Recommendation ITU-R BT.601 Part A, and with the field-blanking definition shown in Table 1.

TABLE 1  
Field interval definitions

		625	525
V-digital field blanking			
Field 1	Start (V = 1)	Line 624	Line 1
	Finish (V = 0)	Line 23	Line 20
Field 2	Start (V = 1)	Line 311	Line 264
	Finish (V = 0)	Line 336	Line 283
F-digital field identification			
Field 1	F = 0	Line 1	Line 4
Field 2	F = 1	Line 313	Line 266

NOTE 1 – Signals F and V change state synchronously with the end of active video timing reference code at the beginning of the digital line.

NOTE 2 – Definition of line numbers is to be found in Recommendation ITU-R BT.470. Note that digital line number changes state prior to O<sub>H</sub> as described in Recommendation ITU-R BT.601 (Part A).

NOTE 3 – Designers should be aware that the “1” to “0” transition of the V-bit may not necessarily occur on line 20 (283) in some equipment conforming to previous versions of this Recommendation for 525-line signals.

## 2.2 Video data format

The data words in which the eight most significant bits are all set to 1 or are all set to 0 are reserved for data identification purposes and consequently only 254 of the possible 256 8-bit words (or 1 016 of the possible 1 024 10-bit words) may be used to express a signal value.

The video data words are conveyed as a 27 Mword/s multiplex in the following order:

$$C_B, Y, C_R, Y, C_B, Y, C_R, \text{ etc.}$$

where the word sequence  $C_B, Y, C_R$ , refers to co-sited luminance and colour-difference samples and the following word,  $Y$ , corresponds to the next luminance sample.

## 2.3 Interface signal structure

Figure 1 shows the ways in which the video sample data is incorporated in the interface data stream. Sample identification in Fig. 1 is in accordance with the identification in Recommendation ITU-R BT.601 (Part A).

FIGURE 1  
Composition of interface data stream

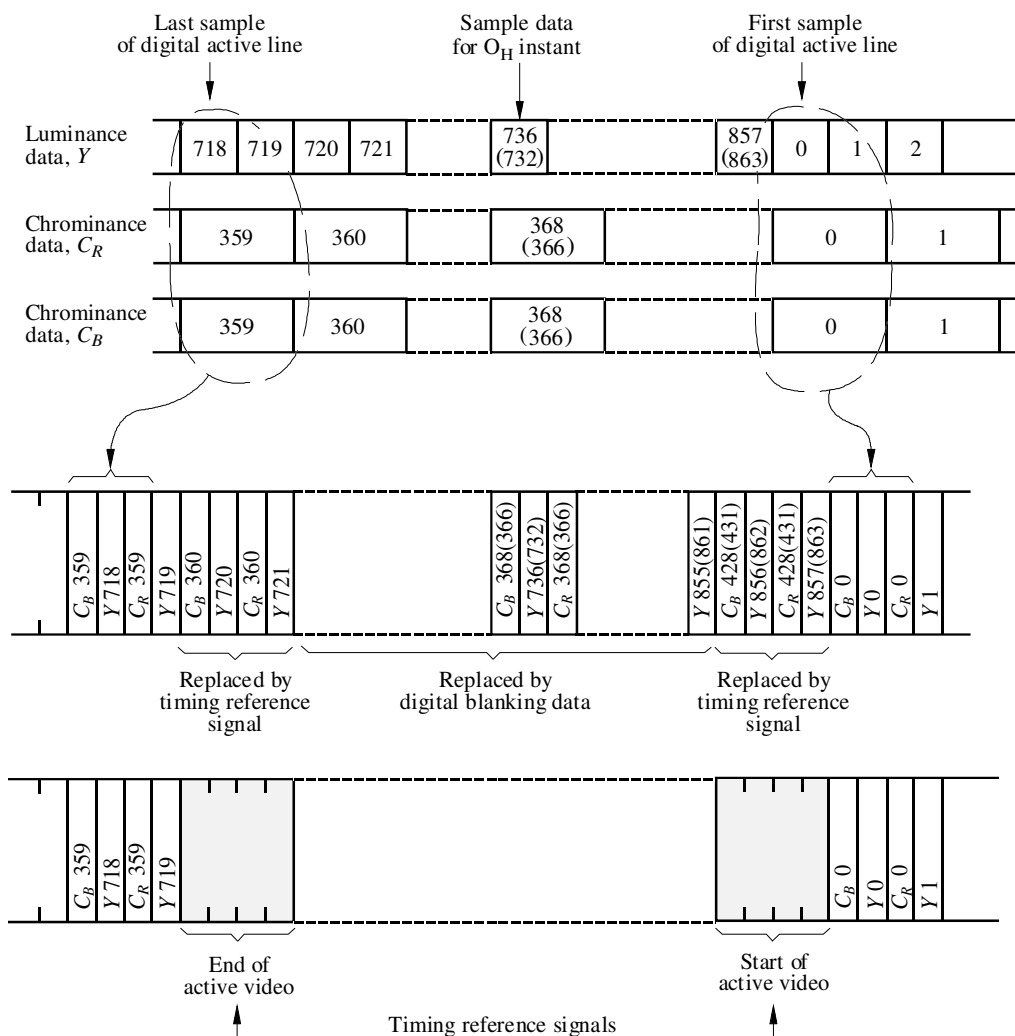

Note 1 – Sample identification numbers in parentheses are for 625-line systems where these differ from those for 525-line systems. (See also Recommendation ITU-R BT.803.)

## 2.4 Video timing reference codes (SAV, EAV)

There are two timing reference signals, one at the beginning of each video data block (start of active video, SAV) and one at the end of each video data block (end of active video, EAV) as shown in Fig. 1.

Each timing reference signal consists of a four word sequence in the following format: FF 00 00 XY. (Values are expressed in hexadecimal notation. FF 00 values are reserved for use in timing reference signals.) The first three words are a fixed preamble. The fourth word contains information defining field 2 identification, the state of field blanking, and the state of line blanking. The assignment of bits within the timing reference signal is shown in Table 2.

TABLE 2  
Video timing reference codes

Data bit number	First word (FF)	Second word (00)	Third word (00)	Fourth word (XY)
9 (MSB)	1	0	0	1
8	1	0	0	F
7	1	0	0	V
6	1	0	0	H
5	1	0	0	P <sub>3</sub>
4	1	0	0	P <sub>2</sub>
3	1	0	0	P <sub>1</sub>
2	1	0	0	P <sub>0</sub>
1 (Note 2)	1	0	0	0
0	1	0	0	0

NOTE 1 – The values shown are those recommended for 10-bit interfaces.

NOTE 2 – For compatibility with existing 8-bit interfaces, the values of bits D<sub>1</sub> and D<sub>0</sub> are not defined.

F = 0 during field 1  
1 during field 2

V = 0 elsewhere  
1 during field blanking

H = 0 in SAV  
1 in EAV

P<sub>0</sub>, P<sub>1</sub>, P<sub>2</sub>, P<sub>3</sub>: protection bits (see Table 3)

MSB: most significant bit

Table 1 defines the state of the V and F bits.

Bits P<sub>0</sub>, P<sub>1</sub>, P<sub>2</sub>, P<sub>3</sub>, have states dependent on the states of the bits F, V and H as shown in Table 3. At the receiver this arrangement permits one-bit errors to be corrected and two-bit errors to be detected.

TABLE 3  
Protection bits

F	V	H	P <sub>3</sub>	P <sub>2</sub>	P <sub>1</sub>	P <sub>0</sub>
0	0	0	0	0	0	0
0	0	1	1	1	0	1
0	1	0	1	0	1	1
0	1	1	0	1	1	0
1	0	0	0	1	1	1
1	0	1	1	0	1	0
1	1	0	1	1	0	0
1	1	1	0	0	0	1

## 2.5 Ancillary data

The ancillary signals should comply with Recommendation ITU-R BT.1364.

## 2.6 Data words during blanking

The data words occurring during digital blanking intervals that are not used for the timing reference code or for ancillary data are filled with the sequence 80.0<sub>h</sub>, 10.0<sub>h</sub>, 80.0<sub>h</sub>, 10.0<sub>h</sub> etc. corresponding to the blanking level of the  $C_B$ ,  $Y$ ,  $C_R$ ,  $Y$  signals respectively, appropriately placed in the multiplexed data.

## PART 2

### Bit-parallel interface

#### 1 General description of the interface

The bits of the digital code words that describe the video signal are transmitted in parallel by means of eight (optionally, ten) conductor pairs, where each carries a multiplexed stream of bits (of the same significance) of each of the component signals,  $C_B$ ,  $Y$ ,  $C_R$ ,  $Y$ . The eight pairs also carry ancillary data that is time-multiplexed into the data stream during video blanking intervals. An additional pair provides a synchronous clock at 27 MHz.

The signals on the interface are transmitted using balanced conductor pairs. Cable lengths of up to 50 m ( $\approx$  160 feet) without equalization and up to 200 m ( $\approx$  650 feet) with appropriate equalization may be employed.

The interconnection employs a twenty-five pin D-subminiature connector equipped with a locking mechanism (see § 5).

For convenience, the bits of the data word are assigned the names DATA 0 to DATA 9. The entire word is designated as DATA (0-9). DATA 9 is the most significant bit. Eight-bit data words occupy DATA (2-9).

Video data is transmitted in NRZ form in real time (unbuffered) in blocks, each comprising one active television line.

#### 2 Data format

The interface carries data in the form of eight (optionally, ten) parallel data bits and a separate synchronous clock. Data is coded in NRZ form. The recommended data format is described in Part 1.

#### 3 Clock signal

##### 3.1 General

The clock signal is a 27 MHz square wave where the 0-1 transition represents the data transfer time. This signal has the following characteristics:

*Width:* 18.5  $\pm$  3 ns

*Jitter:* Less than 3 ns from the average period over one field.

NOTE 1 – This jitter specification, while appropriate for an effective parallel interface, is not suitable for clocking digital-to-analogue conversion or parallel-to-serial conversion.

##### 3.2 Clock-to-data timing relationship

The positive transition of the clock signal shall occur midway between data transitions as shown in Fig. 2.

## 4 Electrical characteristics of the interface

### 4.1 General

Each line driver (source) has a balanced output and the corresponding line receiver (destination) a balanced input (see Fig. 3).

Although the use of ECL technology is not specified, the line driver and receiver must be ECL-compatible, i.e. they must permit the use of ECL for either drivers or receivers.

All digital signal time intervals are measured between the half-amplitude points.

FIGURE 2  
Clock-to-data timing (at source)

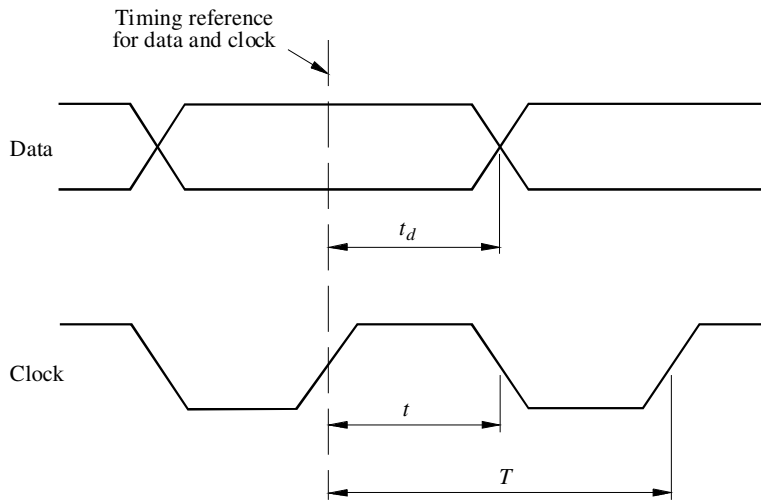

Clock period (625):  $T = \frac{1}{1\,728 f_H} = 37 \text{ ns}$

Clock period (525):  $T = \frac{1}{1\,716 f_H} = 37 \text{ ns}$

Clock pulse width:  $t = 18.5 \pm 3 \text{ ns}$

Data timing – sending end:  $t_d = 18.5 \pm 3 \text{ ns}$

$f_H$ : line frequency

D02

### 4.2 Logic convention

The A terminal of the line driver is positive with respect to the B terminal for a binary 1 and negative for a binary 0 (see Fig. 3).

FIGURE 3  
Line driver and line receiver interconnection

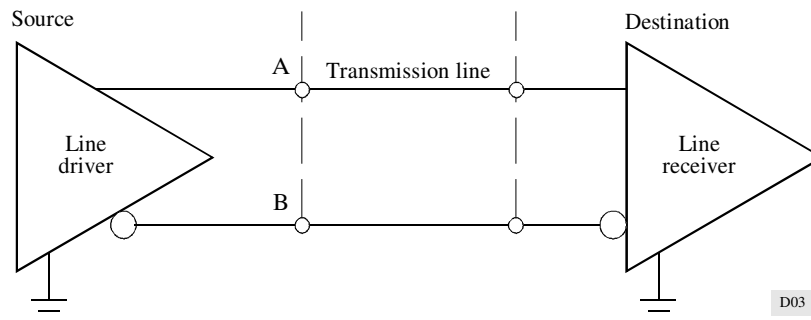

D03

### 4.3 Line driver characteristics (*source*)

4.3.1 *Output impedance*: 110  $\Omega$  maximum.

4.3.2 *Common mode voltage*:  $-1.29 \text{ V} \pm 15\%$  (both terminals relative to ground).

4.3.3 *Signal amplitude*: 0.8 to 2.0 V peak-to-peak, measured across a 110  $\Omega$  resistive load.

4.3.4 *Rise and fall times*: less than 5 ns, measured between the 20% and 80% amplitude points, with a 110  $\Omega$  resistive load. The difference between rise and fall times must not exceed 2 ns.

### 4.4 Line receiver characteristics (*destination*)

4.4.1 *Input impedance*: 110  $\Omega \pm 10 \Omega$ .

4.4.2 *Maximum input signal*: 2.0 V peak-to-peak.

4.4.3 *Minimum input signal*: 185 mV peak-to-peak.

However, the line receiver must sense correctly the binary data when a random data signal produces the conditions represented by the eye diagram in Fig. 4 at the data detection point.

4.4.4 *Maximum common mode signal*:  $\pm 0.5 \text{ V}$ , comprising interference in the range 0 to 15 kHz (both terminals to ground).

4.4.5 *Differential delay*: Data must be correctly sensed when the clock-to-data differential delay is in the range between  $\pm 11 \text{ ns}$  (see Fig. 4).

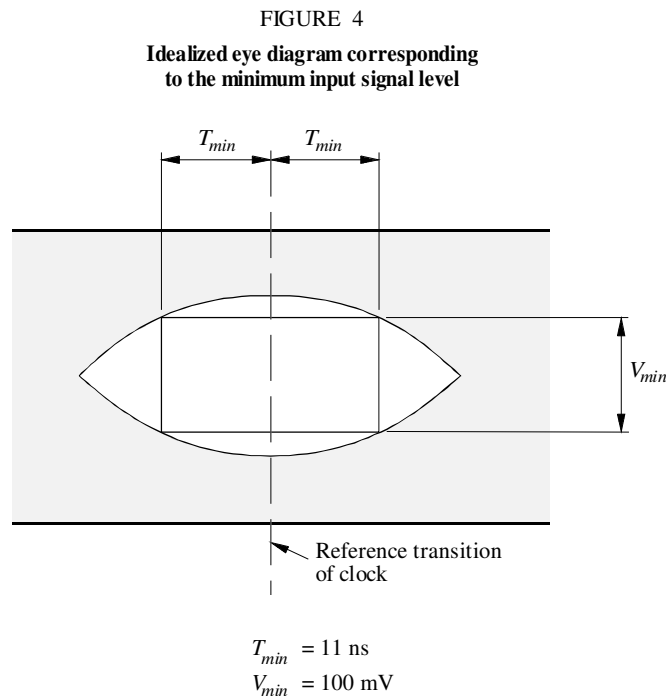

*Note 1* – The width of the window in the eye diagram, within which data must be correctly detected comprises  $\pm 3 \text{ ns}$  clock jitter,  $\pm 3 \text{ ns}$  data timing (see § 3.2),  $\pm 5 \text{ ns}$  available for differences in delay between pairs of the cable. (See also Recommendation ITU-R BT.803.)

D04

## 5 Mechanical details of the connector

The interface uses the 25 contact type D subminiature connector specified in ISO Doc. 2110-1980, with the contact assignment shown in Table 4.

TABLE 4  
Contact assignments

Contact	Signal line
1	Clock
2	System ground A
3	Data 9 (MSB)
4	Data 8
5	Data 7
6	Data 6
7	Data 5
8	Data 4
9	Data 3
10	Data 2
11	Data 1
12	Data 0
13	Cable shield
14	Clock return
15	System ground B
16	Data 9 return
17	Data 8 return
18	Data 7 return
19	Data 6 return
20	Data 5 return
21	Data 4 return
22	Data 3 return
23	Data 2 return
24	Data 1 return
25	Data 0 return

NOTE 1 – The cable shield (contact 13) is for the purpose of controlling electromagnetic radiation from the cable. It is recommended that contact 13 should provide high-frequency continuity to the chassis ground at both ends and, in addition, provide DC continuity to the chassis ground at the sending end. (See also Recommendation ITU-R BT.803.)

Connectors are locked together by two UNC 4-40 screws on the cable connectors, which go in female screw locks mounted on the equipment connector. Cable connectors employ pin contacts and equipment connectors employ socket contacts. Shielding of the interconnecting cable and its connectors must be employed (see Note 1).

NOTE 1 – It should be noted that the ninth and eighteenth harmonics of the 13.5 MHz sampling frequency (nominal value) specified in Recommendation ITU-R BT.601 (Part A) fall at the 121.5 and 243 MHz aeronautical emergency channels. Appropriate precautions must therefore be taken in the design and operation of interfaces to ensure that no interference is caused at these frequencies. Emission levels for related equipment are given in CISPR Recommendation: “Information technology equipment – limits of interference and measuring methods”, Doc. CISPR/B (Central Office) 16. Nevertheless, RR No. 964 prohibits any harmful interference on the emergency frequencies. (See also Recommendation ITU-R BT.803.)

### PART 3

## Bit-serial interface

### 1 General description of the interface

The multiplexed data stream of 10-bit words (as described in Part 1) is transmitted over a single channel in bit-serial form. Prior to transmission, additional coding takes place to provide spectral shaping, word synchronization and to facilitate clock recovery (see Note 1).



NOTE 1 – Previous versions of this Recommendation have described a serial interface based on an 8B9B word-mapping technique. Due to implementation difficulties this technique is no longer recommended.

In addition to the 10-bit interface based on scrambling described in this revision of the Recommendation, there exists an 11-bit word format (10B1C) in which the eleventh bit is the complement of the least significant bit (LSB) of the scrambled data word.

## 2 Coding

The uncoded serial bit-stream is scrambled using the generator polynomial  $G1(x) \times G2(x)$ , where:

$$\begin{aligned} G1(x) &= x^9 + x^4 + 1 && \text{to produce a scrambled NRZ signal, and} \\ G2(x) &= x + 1 && \text{to produce a polarity-free NRZI sequence.} \end{aligned}$$

## 3 Order of transmission

The least significant bit of each 10-bit word shall be transmitted first.

## 4 Logic convention

The signal is transmitted in NRZI form, for which the bit polarity is irrelevant.

## 5 Transmission medium

The bit-serial data stream can be conveyed using either a coaxial cable (see § 6) or fibre-optic bearer (see § 7).

## 6 Characteristics of the electrical interface

### 6.1 Line driver characteristics (source)

#### 6.1.1 Output impedance

The line driver has an unbalanced output with a source impedance of  $75 \Omega$  and a return loss of at least 15 dB over a frequency range of 5-270 MHz.

#### 6.1.2 Signal amplitude

The peak-to-peak signal amplitude lies between  $800 \text{ mV} \pm 10\%$  measured across a  $75 \Omega$  resistive load directly connected to the output terminals without any transmission line.

#### 6.1.3 d.c. offset

The d.c. offset with reference to the mid-amplitude point of the signal lies between + 0.5 and - 0.5 V.

#### 6.1.4 Rise and fall times

The rise and fall times, determined between the 20% and 80% amplitude points and measured across a  $75 \Omega$  resistive load connected directly to the output terminals, shall lie between 0.75 and 1.50 ns and shall not differ by more than 0.50 ns.

#### 6.1.5 Jitter

The output jitter is specified as follows:

$$\begin{aligned} \text{Output jitter (see Note 1)} \quad f_1 &= 10 \text{ Hz} \\ f_3 &= 100 \text{ kHz} \\ f_4 &= 1/10 \text{ of the clock rate} \\ A_1 &= 0.2 \text{ UI (UI; unit interval) (see Note 2)} \\ A_2 &= 0.2 \text{ UI} \end{aligned}$$

NOTE 1 – 1 UI and 0.2 UI correspond to 3.7 ns and 0.74 ns.

Specification of jitter and jitter measurements methods shall comply with Recommendation ITU-R BT.1363 (Jitter specifications and jitter measurement methods of bit-serial signals conforming to Recommendations ITU-R BT.656, ITU-R BT.799 and ITU-R BT.1120).

NOTE 2 – 0.2 UI for timing jitter is often used in other specifications. There are considerations in specifying 1 UI for timing jitter.

## 6.2 Line receiver characteristics (*destination*)

### 6.2.1 Terminating impedance

The cable is terminated by 75  $\Omega$  with a return loss of at least 15 dB over a frequency range of 5-270 MHz.

### 6.2.2 Receiver sensitivity (*see Note 1*)

The line receiver must sense correctly random binary data when either connected to a line driver operating at the extreme voltage limits permitted by § 6.1.2 or when connected via a cable having a loss of 40 dB at 270 MHz and a loss characteristic of  $1/\sqrt{f}$ .

NOTE 1 – Parameters defined in § 6.1.5, 6.2.2 and 6.2.3 are target values and may be refined in the future with regard to practical implementations of the system.

### 6.2.3 Interference rejection (*see Note 1*)

When connected directly to a line driver operating at the lower limit specified in § 6.1.2, the line receiver must sense correctly the binary data in the presence of a superimposed interfering signal at the following levels:

d.c.	$\pm 2.5$ V
Below 1 kHz:	2.5 V peak-to-peak
1 kHz to 5 MHz:	100 mV peak-to-peak
Above 5 MHz:	40 mV peak-to-peak

NOTE 1 – Parameters defined in § 6.1.5, 6.2.2 and 6.2.3 are target values and may be refined in the future with regard to practical implementations of the system.

### 6.2.4 Input jitter

Input jitter tolerances needs to be defined. Input jitter is measured with a short cable (2 m).

Specification of jitter and jitter measurements methods shall comply with Recommendation ITU-R BT.1363 (Jitter specifications and jitter measurement methods of bit-serial signals conforming to Recommendations ITU-R BT.656, ITU-R BT.799 and ITU-R BT.1120).

## 6.3 Cables and connectors

### 6.3.1 Cable

It is recommended that the cable chosen should meet any relevant national standards on electromagnetic radiation.

NOTE 1 – It should be noted that the ninth and eighteenth harmonics of the 13.5 MHz sampling frequency (nominal value) specified in Recommendation ITU-R BT.601 (Part A) fall at the 121.5 and 243 MHz aeronautical emergency channels. Appropriate precautions must therefore be taken in the design and operation of interfaces to ensure that no interference is caused at these frequencies. Emission levels for related equipment are given in CISPR Recommendation: “Information technology equipment – limits of interference and measuring methods” (Doc. CISPR/B (Central Office) 16). Nevertheless, RR No. 964 prohibits any harmful interference on the emergency frequencies. (See also Recommendation ITU-R BT.803.)

### 6.3.2 Characteristic impedance

The cable used shall have a nominal characteristic impedance of 75  $\Omega$ .

### 6.3.3 Connector characteristics

The connector shall have mechanical characteristics conforming to the standard BNC type (IEC Publication 169-8), and its electrical characteristics should permit it to be used at frequencies up to 850 MHz in 75  $\Omega$  circuits.

## 7 Characteristics of the optical interface

Specifications for the characteristics of the optical interface should comply with general rules of Recommendation ITU-R BT.1367 (Serial Digital Fiber Transmission Systems for Signals Conforming to Recommendations ITU-R BT.656, ITU-R BT.799 and ITU-R BT.1120).

To make use of this Recommendation the following specifications are necessary:

Rise and fall times	< 1.5ns (20% to 80%)
Output jitter (see Note 1)	$f_1 = 10$ Hz
	$f_3 = 100$ kHz
	$f_4 = 1/10$ of the clock rate
	$A_1 = 0.135$ UI (UI; unit interval)
	$A_2 = 0.135$ UI

Input jitter needs to be defined. Input jitter is measured with a short cable (2 m).

NOTE 1 - Specification of jitter and jitter measurements methods shall comply with Recommendation ITU-R BT.1363 (Jitter specifications and jitter measurement methods of bit-serial signals conforming to Recommendations ITU-R BT.656, ITU-R BT.799 and ITU-R BT.1120).

## ANNEX 1

### Notes concerning interfaces for digital video signals in 525-line and 625-line television systems

#### 1 Introduction

This Annex includes supplementary information on subjects not yet fully specified, and indicates studies in which further work is required.

#### 2 Definitions

Interface is a concept involving the specification of the interconnection between two items of equipment or systems. The specification includes the type, quantity and function of the interconnection circuits and the type and form of the signals to be interchanged by these circuits.

A parallel interface is an interface in which the bits of a data word are sent simultaneously via separate channels.

A serial interface is an interface in which the bits of a data word, and successive data words, are sent consecutively via a single channel.

#### 3 Parallel interfaces

Appropriate coding of the clock signal, such as the use of an alternating parity (AP) coding, has been shown to extend the interconnection distance by reducing the effects of cable attenuation.

To permit correct operation with longer interconnection links, the line receiver may incorporate equalization.

When equalization is used, it may conform to the nominal characteristic of Fig. 5. This characteristic permits operation with a range of cable lengths down to zero. The line receiver must satisfy the maximum input signal condition of § 4.4 of Part 2 of this Recommendation.

FIGURE 5  
Line receiver equalization characteristic for small signals

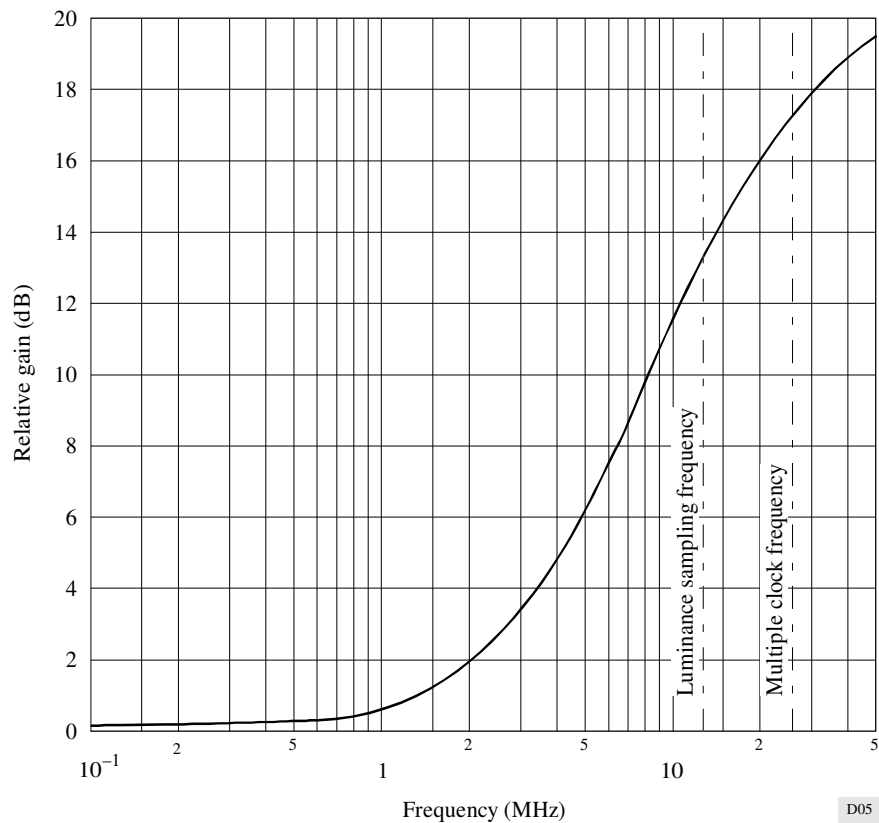

## 4 Serial interfaces

The transmission of signals can be achieved in both electrical form, using coaxial cable, and in optical form using an optical fibre. Coaxial cables would probably be preferred for connections of medium length, while preference would go to optical fibres for very long connection lengths.

It is possible to implement a system for detection of the occurrence of errors at the receiving end of the connection and thus automatically monitoring its performance.

In a fully integrated digital installation or system it may be useful for all interconnections to be transparent to any appropriate digital stream, irrespective of the message content. Thus, although the interface will be used to transmit a video signal, it should be “transparent” to the message content, i.e. it should not base its operation on the known structure of the message itself.

Development work is ongoing on the subject of serial interfaces. In the context of the European Race projects, for example, fibre optic routing systems which can accept a variety of input formats are assembled as part of a pilot installation.

## 5 Interference with other services

Processing and transmission of digital data, such as digital video signals at high data rates produces a wide spectrum of energy that has the potential to cause cross-talk or interference. In particular, attention is drawn in the present Recommendation to the fact that the ninth and eighteenth harmonics of the 13.5 MHz sampling frequency (nominal value) specified in Recommendation ITU-R BT.601 (Part A) fall at the 121.5 and 243 MHz aeronautical emergency channels. Appropriate precautions must therefore be taken in the design and operation of interfaces to ensure that no interference is caused at these frequencies. Permitted maximum levels of radiated signals from digital data processing equipment are the subject of various national and international standards, and it should be noted that emission levels for such related equipment are given in CISPR Recommendation: "Information technology equipment – Limits of interference and measuring methods", Doc. CISPR/B (Central Office) 16.

In the case of the bit-parallel interface, work carried out by the Canadian Broadcasting Corporation (CBC) indicates that, with a correct shielding of the cables, no interference problem with other services is to be expected. Radiation levels should comply with the limits given in Table 5. These limits are equivalent to those of the FCC in the United States of America.

TABLE 5

### Limits of spurious emissions

Frequency (MHz)	Maximum field strength at 30 m (dB( $\mu$ V/m))
30-88	30
88-216	50
216-1 000	70

Transmission by optical fibres eliminates radiation generated by the cable and also prevents conducted common-mode radiation, but the performance of coaxial cable can also be made near-perfect. It is believed that the major portion of any radiation would be from the processing logic and high-power drivers common to both methods. Due to the wideband, random nature of the digital signal, little is gained by frequency optimization.

## 6 Conclusion

Further studies are required on the practical methods required to ensure acceptably low levels of radiated interference from the digital signals.

---

