



## 61C In the News

### FCC chief declares AT&T/T-Mobile merger a turkey, prepares it for slaughter

Administrative hearing could spell death knell of proposed \$39 billion merger

*By Brad Reed, Network World  
November 22, 2011 06:05 PM ET*

AT&T's proposed merger with T-Mobile has come under criticism from consumer groups, rival wireless carrier Sprint and analyst firms such as the Yankee Group, who contend that the merger will lead to the emergence of a duopolistic wireless telecom market controlled largely by Verizon and AT&T. ... AT&T would become by far the largest wireless carrier in the United States with more than 130 million subscribers.

11/22/11 Fall 2011 -- Lecture #37 1

## CS 61C: Great Ideas in Computer Architecture (Machine Structures)

### Lecture 37: IO and Networking

Instructors:  
Mike Franklin  
Dan Garcia

<http://inst.eecs.Berkeley.edu/~cs61c/Fa11>

11/22/11 Fall 2011 -- Lecture #37 2

## Review

- I/O gives computers their 5 senses + long term memory
- I/O speed range is 7 Orders of Magnitude (or more!)
- Processor speed means must synchronize with I/O devices before use
- Polling works, but expensive
  - processor repeatedly queries devices
- Interrupts work, but more complex
  - we'll talk about these today

11/22/11 Fall 2011 -- Lecture #37 3

## Exceptions and Interrupts

- “Unexpected” events requiring change in flow of control
  - Different ISAs use the terms differently
- Exception
  - Arises within the CPU
    - e.g., Undefined opcode, overflow, syscall, TLB Miss,...
- Interrupt
  - From an external I/O controller
- Dealing with them without sacrificing performance is difficult

11/22/11 Fall 2011 -- Lecture #37 4

## Handling Exceptions

- In MIPS, exceptions managed by a System Control Coprocessor (CPO)
- Save PC of offending (or interrupted) instruction
  - In MIPS: save in special register called **Exception Program Counter (EPC)**
- Save indication of the problem
  - In MIPS: saved in special register called **Cause** register
  - We'll assume 1-bit
    - 0 for undefined opcode, 1 for overflow
- Jump to exception handler code at address **8000 0180<sub>hex</sub>**

11/22/11 Fall 2011 -- Lecture #37 5

## Exception Properties

- Restartable exceptions
  - Pipeline can flush the instruction
  - Handler executes, then returns to the instruction
    - Refetched and executed from scratch
- PC saved in EPC register
  - Identifies causing instruction
  - Actually PC + 4 is saved because of pipelined implementation
    - Handler must adjust PC to get right address

11/22/11 Fall 2011 -- Lecture #37 6

### Handler Actions

- Read Cause register, and transfer to relevant handler
- Determine action required
- If restartable exception
  - Take corrective action
  - use EPC to return to program
- Otherwise
  - Terminate program
  - Report error using EPC, cause, ...

11/22/11

Fall 2011 – Lecture #37

7

### Exceptions in a Pipeline

- Another kind of control hazard
- Consider overflow on add in EX stage
  - Prevent \$1 from being clobbered
  - Complete previous instructions
  - Flush add and subsequent instructions
  - Set Cause and EPC register values
  - Transfer control to handler
- Similar to mispredicted branch
  - Use much of the same hardware

11/22/11

Fall 2011 – Lecture #37

8

### Exception Example

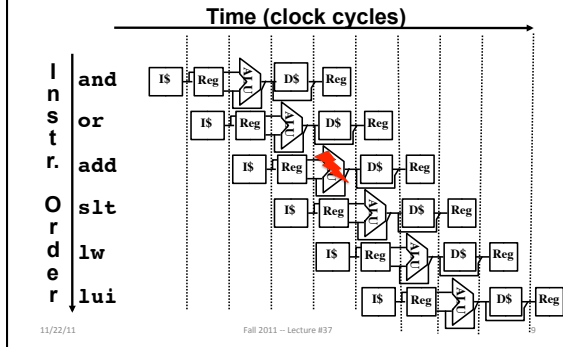

11/22/11

Fall 2011 – Lecture #37

9

### Exception Example

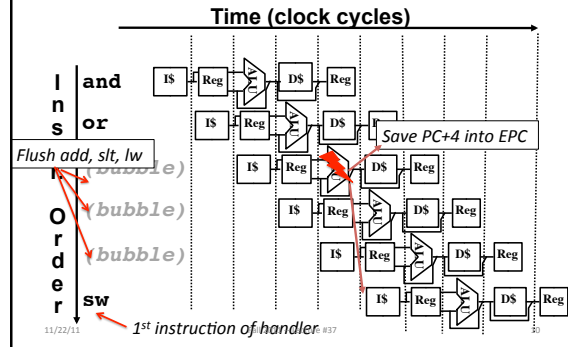

11/22/11

Fall 2011 – Lecture #37

10

### Multiple Exceptions

- Pipelining overlaps multiple instructions
  - Could have multiple exceptions at once
  - E.g., Page fault in LW same clock cycle as Overflow of following instruction ADD
- Simple approach: deal with exception from *earliest* instruction, e.g., LW exception serviced 1st
  - Flush subsequent instructions
- Called *Precise* exceptions
- In complex pipelines:
  - Multiple instructions issued per cycle
  - Out-of-order completion
  - Maintaining precise exceptions is difficult!

11/22/11

Fall 2011 – Lecture #37

11

### Imprecise Exceptions

- Just stop pipeline and save state
  - Including exception cause(s)
- Let the software handler work out
  - Which instruction(s) had exceptions
  - Which to complete or flush
    - May require "manual" completion
- Simplifies hardware, but more complex handler software
- Not feasible for complex multiple-issue out-of-order pipelines to always get exact instruction
- All computers today offer precise exceptions—affects performance though

11/22/11

Fall 2011 – Lecture #37

12

## I/O Interrupt

- An I/O interrupt is like an exception except:
  - An I/O interrupt is “asynchronous”
  - More information needs to be conveyed
- An I/O interrupt is asynchronous with respect to instruction execution:
  - I/O interrupt is not associated with any instruction, but it can happen in the middle of any given instruction
  - I/O interrupt does not prevent any instruction from completion

## Interrupt-Driven Data Transfer

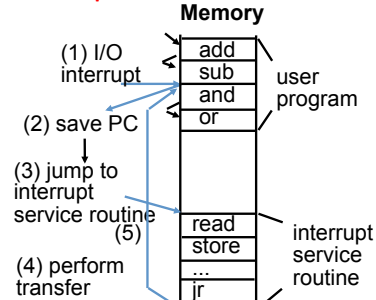

## Benefit of Interrupt-Driven I/O

- Find the % of processor consumed if the hard disk is only active 5% of the time. Assuming 500 clock cycle overhead for each transfer, including interrupt:
  - Disk Interrupts/s =  $5\% * 16 \text{ [MB/s]} / 16 \text{ [B/interrupt]} = 50,000 \text{ [interrupts/s]}$
  - Disk Interrupts [clocks/s] =  $50,000 \text{ [interrupts/s]} * 500 \text{ [clocks/interrupt]} = 25,000,000 \text{ [clocks/s]}$
  - % Processor for during transfer:  $2.5 * 10^7 \text{ [clocks/s]} / 1 * 10^9 \text{ [clocks/s]} = \mathbf{2.5\% \text{ Busy}}$
- DMA (Direct Memory Access) even better – only one interrupt for an entire page!

## Networks: Talking to the Outside World

- Originally sharing I/O devices between computers
  - E.g., printers
- Then communicating between computers
  - E.g., file transfer protocol
- Then communicating between people
  - E.g., e-mail
- Then communicating between networks of computers
  - E.g., file sharing, www, ...

[www.computerhistory.org/internet\\_history](http://www.computerhistory.org/internet_history)

## The Internet (1962)

- Founders
  - JCR Licklider, as head of ARPA, writes on “intergalactic network”
  - 1963 : ASCII becomes first universal computer standard
  - 1969 : Defense Advanced Research Projects Agency (DARPA) deploys 4 “nodes” @ UCLA, SRI, Utah, & UCSB
  - 1973 Robert Kahn & Vint Cerf invent TCP, now part of the Internet Protocol Suite
- Internet growth rates
  - Exponential since start!

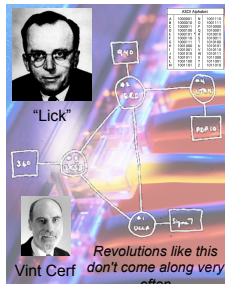

[en.wikipedia.org/wiki/History\\_of\\_the\\_World\\_Wide\\_Web](http://en.wikipedia.org/wiki/History_of_the_World_Wide_Web)

## The World Wide Web (1989)

- “System of interlinked hypertext documents on the Internet”
- History
  - 1945: Vannevar Bush describes hypertext system called “memex” in article
  - 1989: Tim Berners-Lee proposes, gets system up '90
  - ~2000 Dot-com entrepreneurs rushed in, 2001 bubble burst
- Wayback Machine
  - Snapshots of web over time
- Today : Access anywhere!

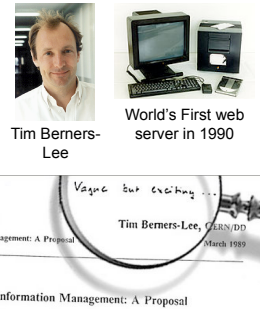

### Shared vs. Switched Based Networks

- Shared vs. Switched:
  - Shared: 1 at a time (CSMA/CD)
  - Switched: pairs ("point-to-point" connections) communicate at same time
- Aggregate bandwidth (BW) in switched network is many times shared:
  - point-to-point faster since no arbitration, simpler interface

11/22/11 Fall 2011 - Lecture #37 19

### What makes networks work?

- links connecting switches and/or routers to each other and to computers or devices
- ability to name the components and to route packets of information - messages - from a source to a destination
- Layering, redundancy, protocols, and encapsulation as means of abstraction (61C big idea)

11/22/11 Fall 2011 - Lecture #37 20

### Software Protocol to Send and Receive

- SW Send steps
  - Application copies data to OS buffer
  - OS calculates checksum, starts timer
  - OS sends data to network interface HW and says start
- SW Receive steps
  - OS copies data from network interface HW to OS buffer
  - OS calculates checksum, if OK, send ACK; if not, delete message (sender resends when timer expires)
  - If OK, OS copies data to user address space, & signals application to continue

Dest	Src	Checksum
Net ID	Net ID	ACK INFO
Len	CMD/ Address /Data	

Header Payload Trailer

11/22/11 Fall 2011 - Lecture #37 21

### Protocol for Networks of Networks?

- Abstraction to cope with complexity of communication
- Networks are like onions
  - Hierarchy of layers:
    - Application (chat client, game, etc.)
    - Transport (TCP, UDP)
    - Network (IP)
    - Physical Link (wired, wireless, etc.)

Networks are like onions. They stink? Yes. No! Oh, they make you cry. No!... Layers. Onions have layers. Networks have layers.

11/22/11 Fall 2011 - Lecture #37 22

### Protocol Family Concept

- Key to protocol families is that communication occurs logically at the same level of the protocol, called peer-to-peer...
  - ...but is implemented via services at the next lower level
- Encapsulation: carry higher level information within lower level "envelope"
- Fragmentation: break packet into multiple smaller packets and reassemble

11/22/11 Fall 2011 - Lecture #37 23

### Protocol Family Concept

11/22/11 Fall 2011 - Lecture #37 24

## Protocol for Network of Networks

- [Transmission Control Protocol/Internet Protocol \(TCP/IP\)](#)  
(TCP :: a Transport Layer)
  - This protocol family is the **basis of the Internet**, a WAN protocol
  - IP makes best effort to deliver
    - Packets can be lost, corrupted
  - TCP guarantees delivery
  - TCP/IP so popular it is used even when communicating locally: even across homogeneous LAN

11/22/11

Fall 2011 -- Lecture #37

25

## TCP/IP packet, Ethernet packet, protocols

- Application sends message
- TCP breaks into 64KiB segments, adds 20B header
- IP adds 20B header, sends to network
- If Ethernet, broken into 1500B packets with headers, trailers (24B)

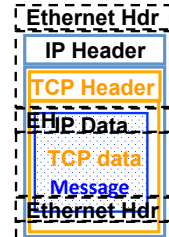

11/22/11

Fall 2011 -- Lecture #37

26

## And in conclusion...

- Exceptions are “Unexpected” events
- Interrupts are asynchronous
  - can be used for interacting with I/O devices
- Need to handle in presence of pipelining, etc.
- Networks are another form of I/O
- Protocol suites allow networking of heterogeneous components
  - Another form of principle of abstraction
- Interested in Networking?
  - EE122 (CS-based in Fall, EE –based in Spring)

11/22/11

Fall 2011 -- Lecture #37

27